

EXPLORE

The Beauty of Intricacy

“

Ludwig Mies van der Rohe

GOD IS
IN THE
DETAILS

”



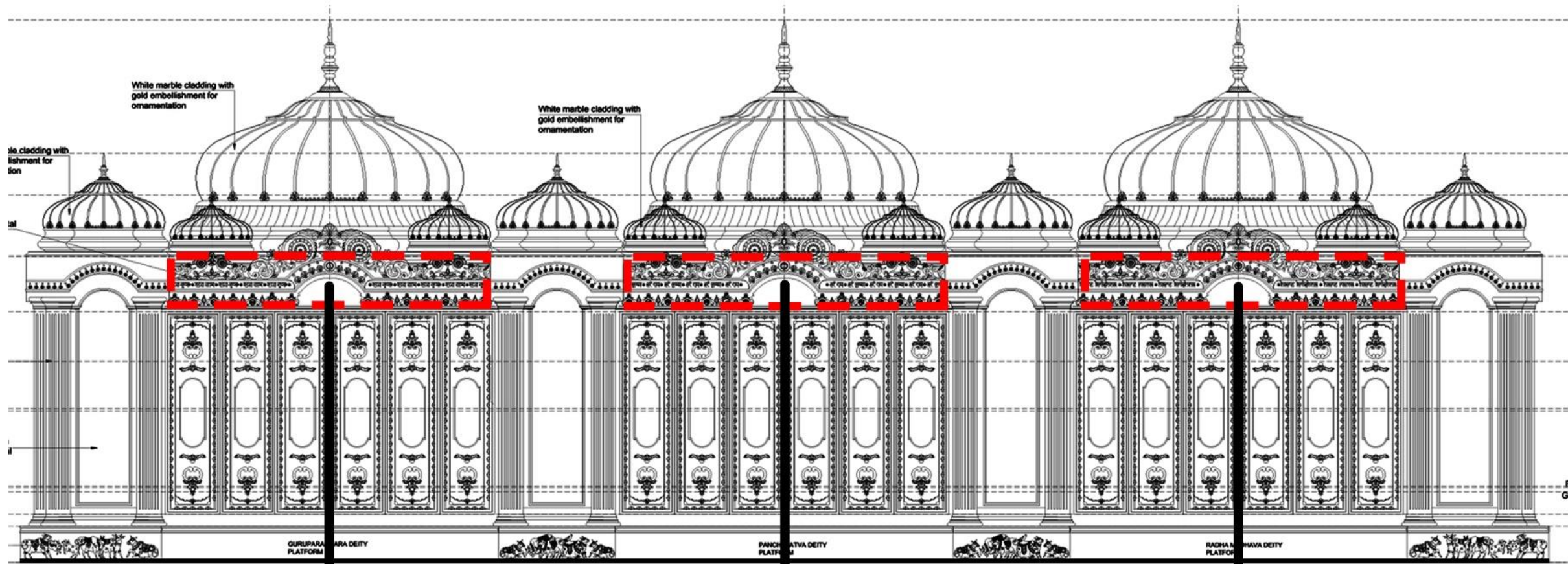

MOTIFS ON FRIEZE - THE NARRATIVE

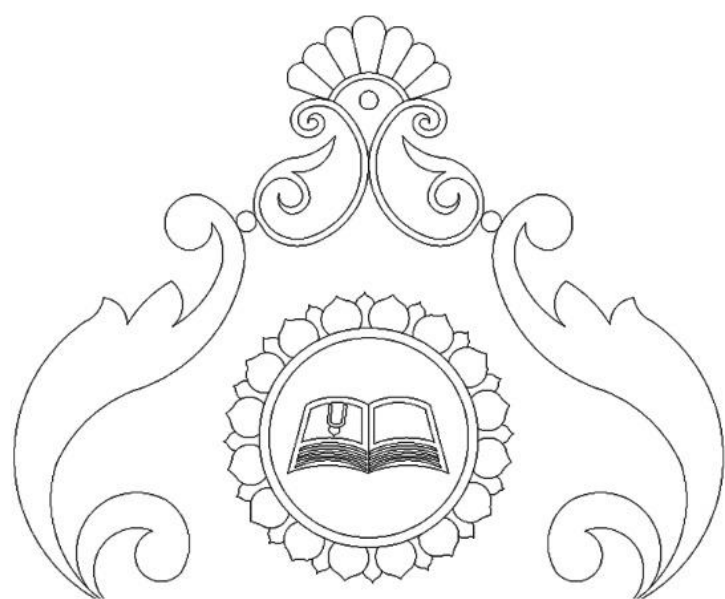
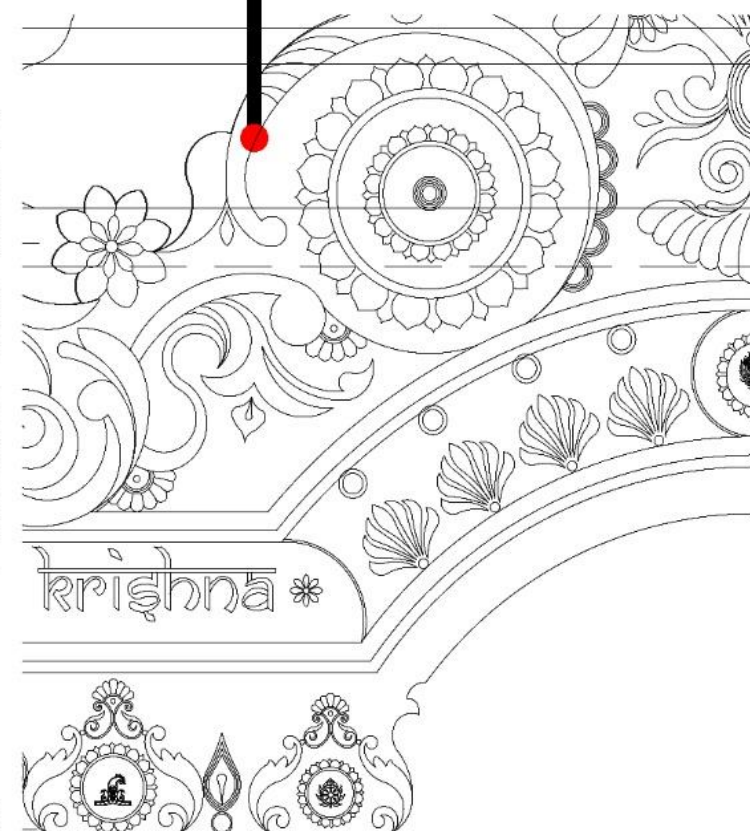
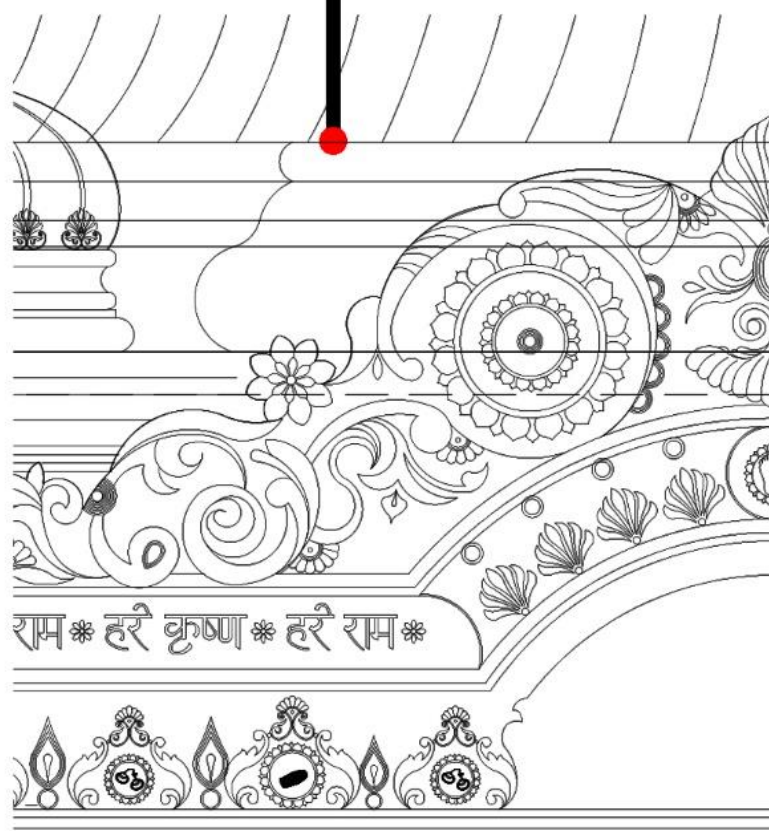

GURUPARAMPARA
TRANSMISSION OF KNOWLEDGE

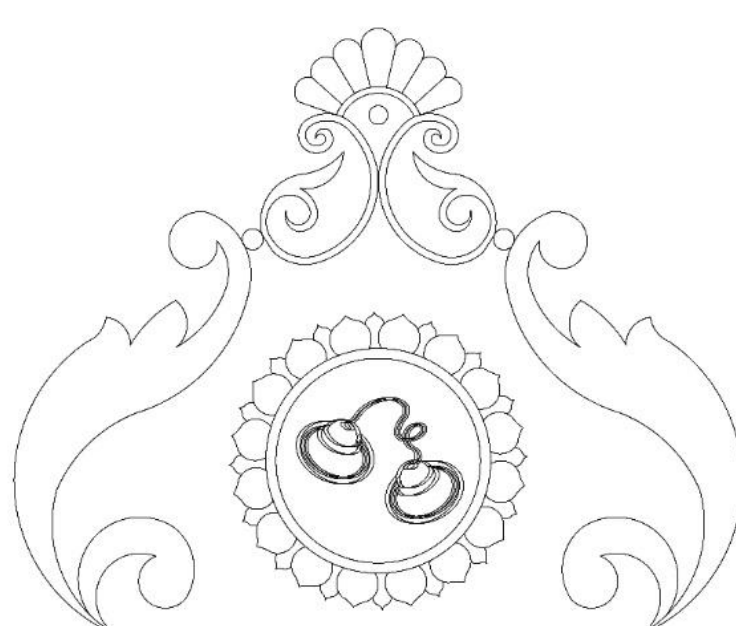

PANCHATATTVA
INAUGURATION OF
SANKIRTAN MOVEMENT

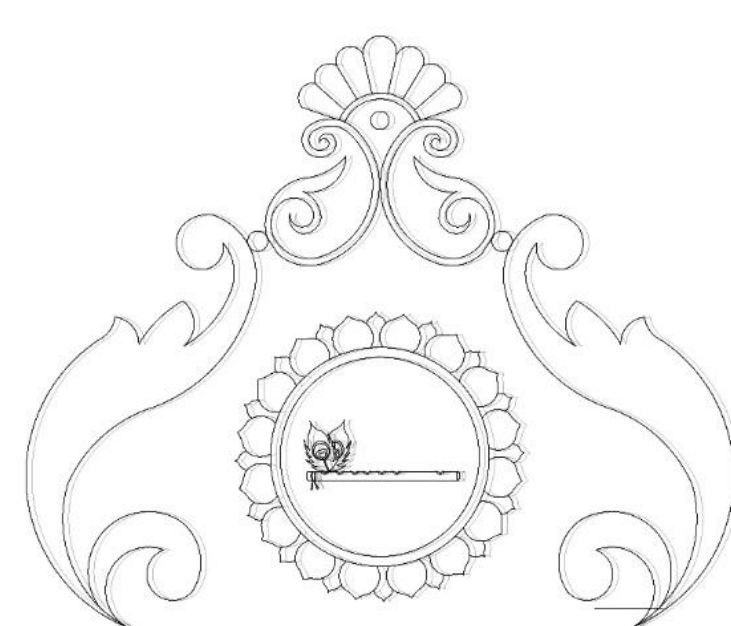

RADHAMADHAVA
GOLOKA VRINDAVAN

Transmission of knowledge from the Bhagwat Gita. Holy names, scriptures, Shells etc.

Mridang, Kirtan, Kartal, Mahamantra, ISKCON Logo, Hare Krishna Mahamantra

Sudarshan Chakra, Lotus Feet, Gardens, Flute, Radharani Crown, Tilak Motifs, Peacock feather

SYMBOLIC REPRESENTATION

Material Palette



Vietnam white marble



Gold Plated Metal

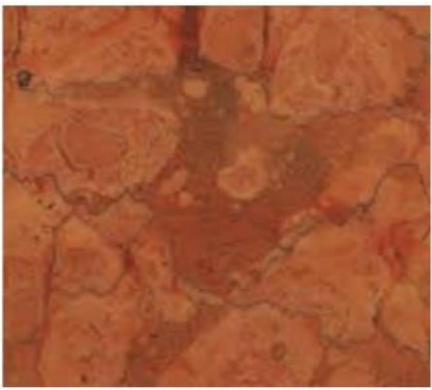

Red Verona



Black marble

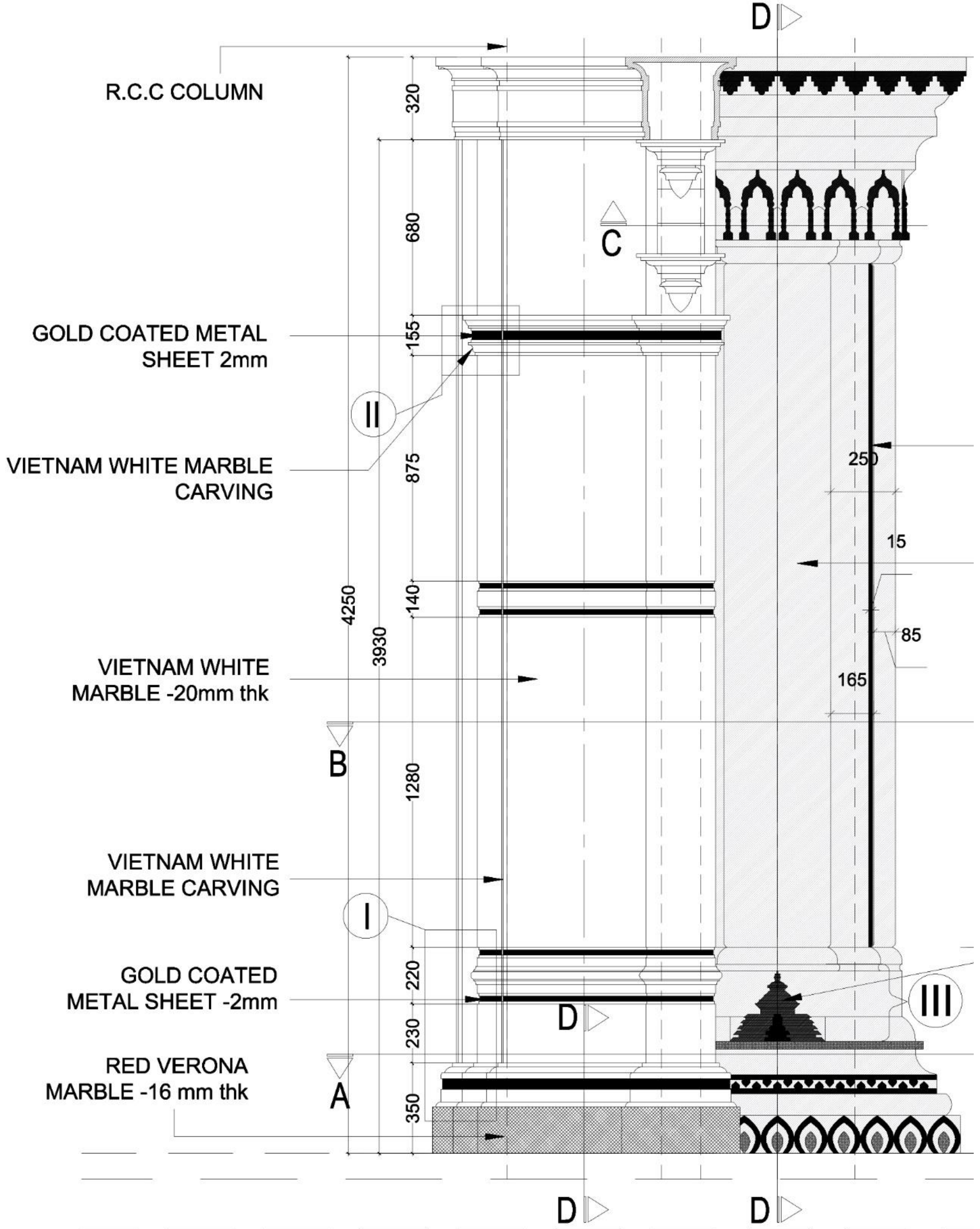

Column Capital, base and ornamentation details

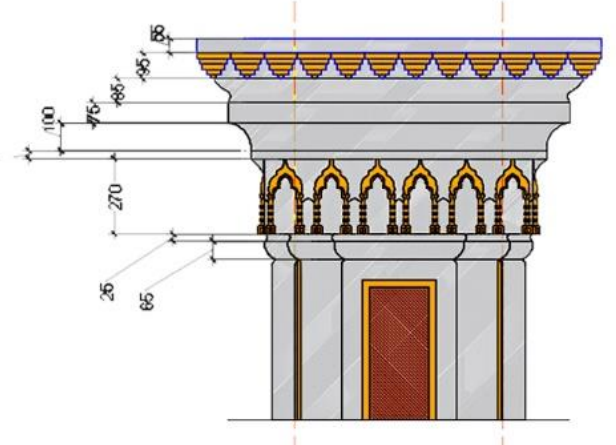
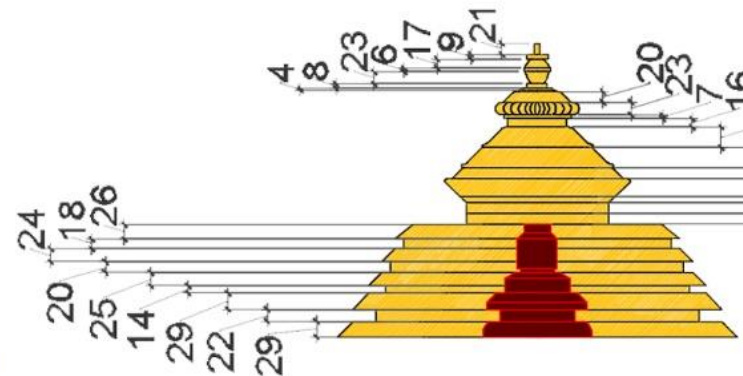
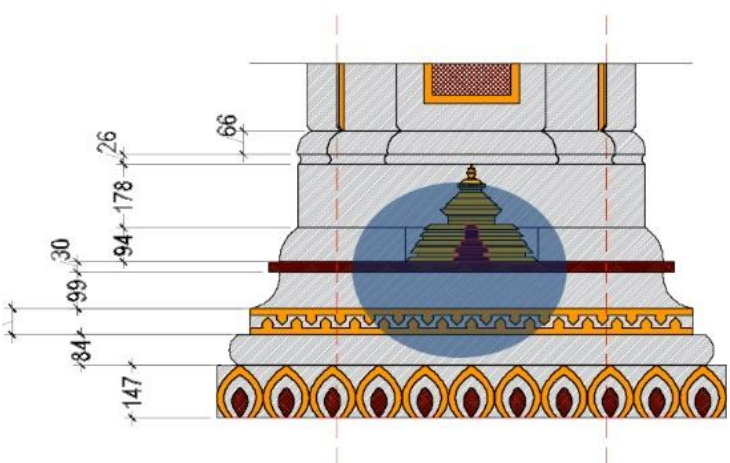

FRONT ELEVATION

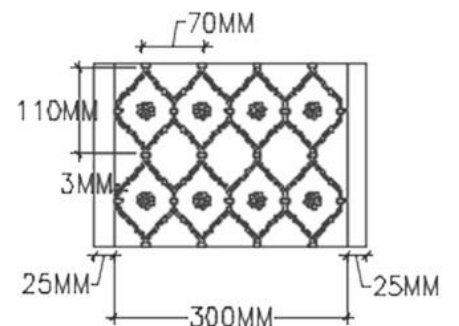
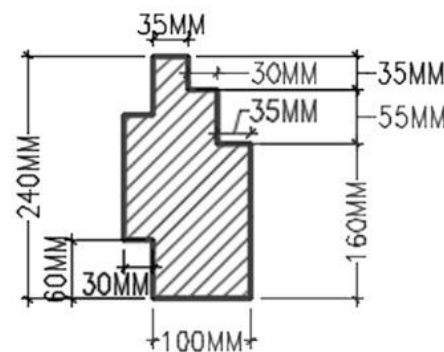
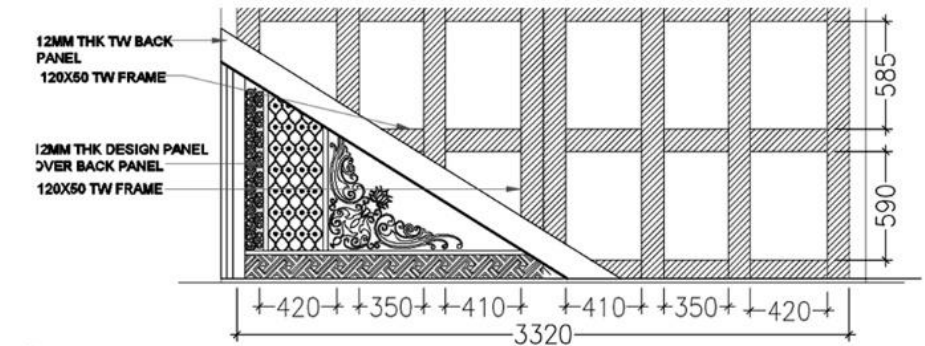
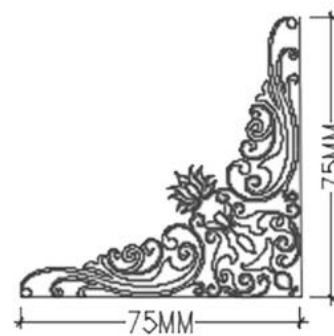
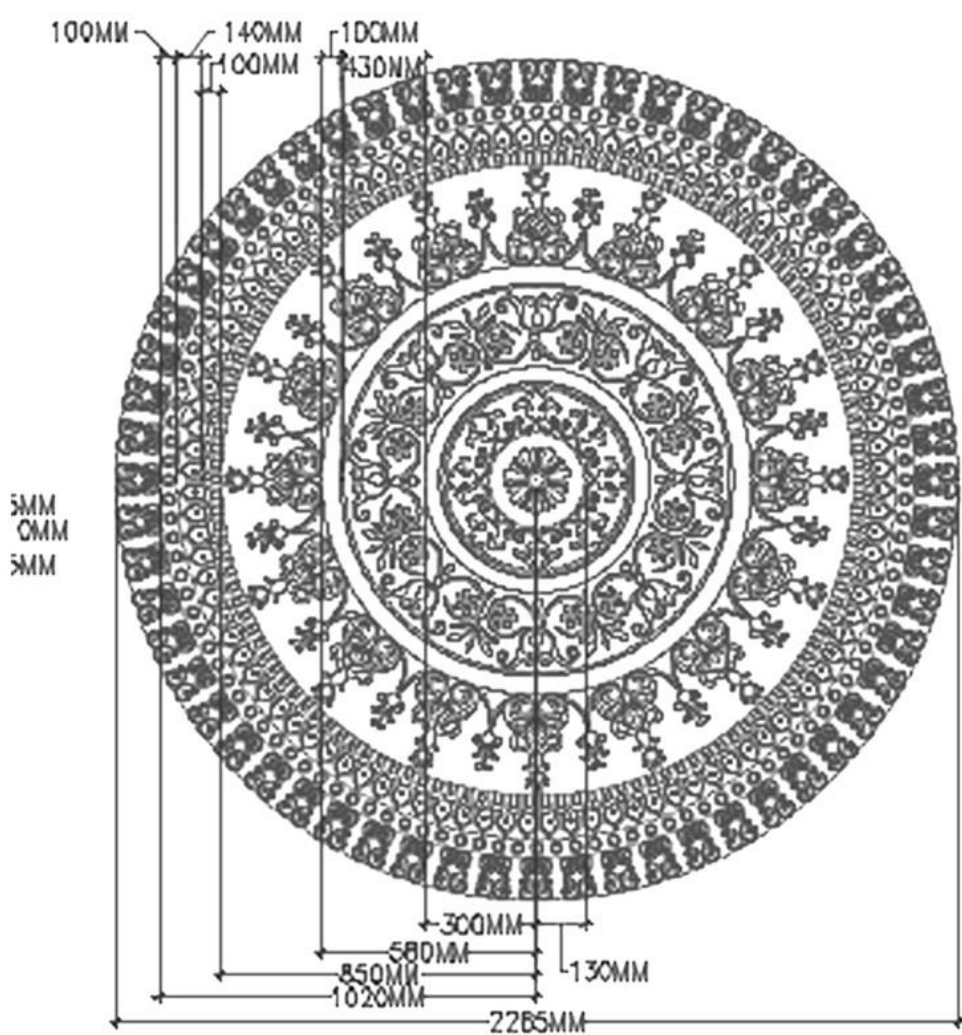
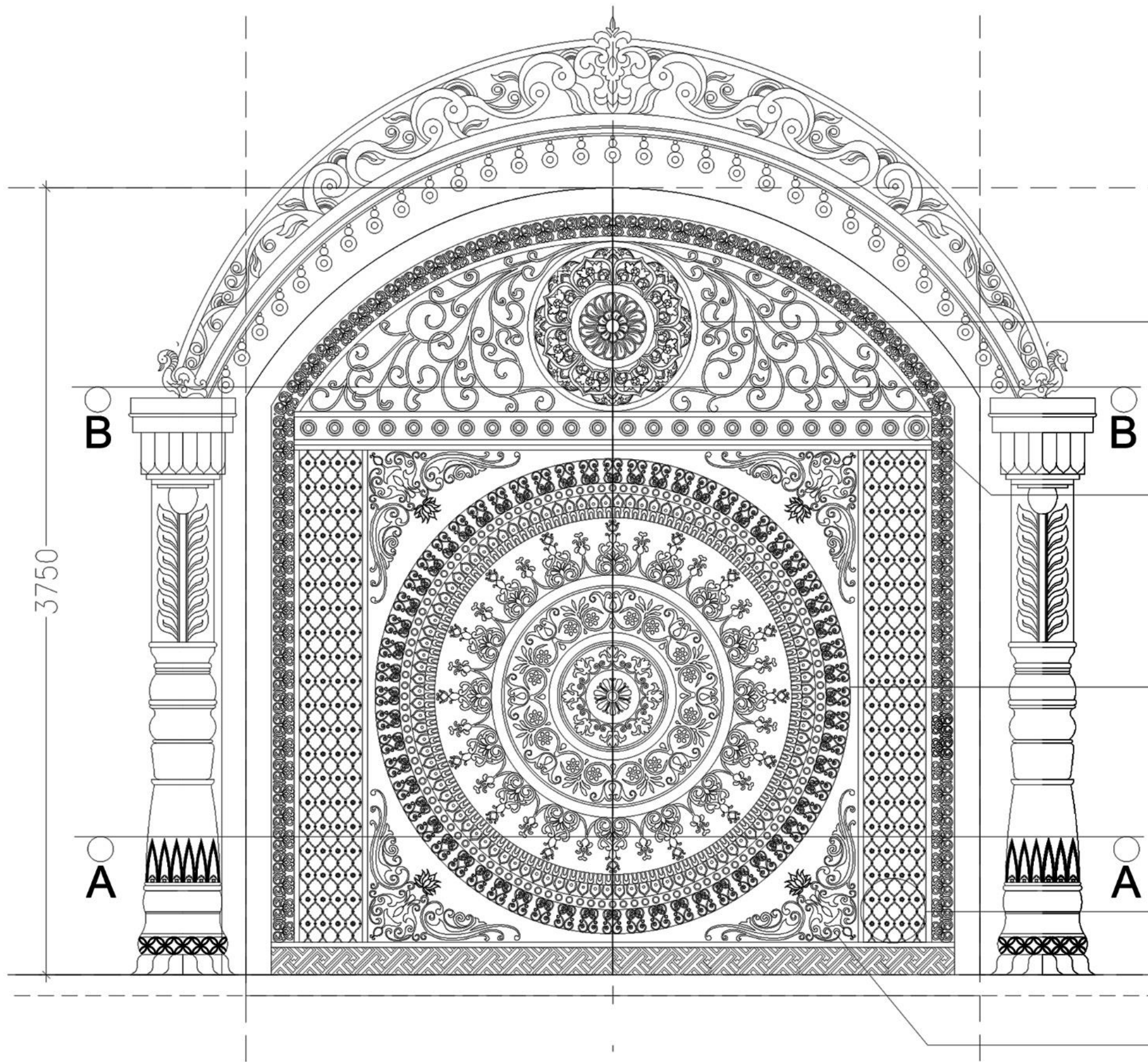

DOOR DETAILS



ARCHITECT OF THE WEEK

SANDARBH RAJPUT

DESIGN DEVELOPMENT ARCHITECT

HIS SHARING

The Temple gave Sandarbh the liberty of detail designing along with decision making. Working and coordinating with various departments is something new that he thoroughly relishes here. *'The positive vibe and spirituality that surrounds the team and this project encourages me to work more efficiently everyday.'*

QUALIFICATION

B.Arch- Pune
University, Registered
with The **Council of
Architecture, Delhi**
Diploma in Interior
Design- MMSID

INTERESTS AND AWARDS

Principal Architect -
Arteffects

CONTRIBUTIONS TO THE TOVP

Sandarbh possesses a high level of responsibility, commitment and punctuality. He thrives on thrashing down the complex building elements into fundamental parts by harnessing the building technology.